

**APPROVED**

By Mario.Escamilla at 2:02 pm, 5/12/05



# 556L General Motors Passlock Interface Module

## Product Description

The 556L General Motors Passlock Interface Module is used when installing remote start products in GM vehicles equipped with Passlock I and Passlock II anti-theft systems. The 556L provides easy interfacing while maintaining the integrity of the vehicle's anti-theft system. The 556L interfaces with the Passlock systems by providing the proper Resistance Code (R-Code) at the appropriate time. The 556L will also provide, when necessary, a negative signal to the bulb check wire. The 556L has no effect on the Passlock system when the remote start is not in use. The factory Passlock anti-theft system will remain fully functional.

**IMPORTANT!** Before beginning the installation, make sure that you are connecting to the correct type of Passlock system (either Passlock I, Passlock II or alternate). You can determine which type of system is being used by referencing the Vehicle Application Guide section in this manual.

## Passlock System Details

The GM Passlock System is a key-based, fuel shutdown, anti-theft system. The Passlock system requires that the key cylinder be mechanically turned using a key. When the key cylinder is properly turned, it generates the R-Code, which is sent to the Instrument Panel Cluster (IPC) in Passlock I systems or the Body Control Module (BCM) in Passlock II systems. The IPC and the BCM both house the Passlock decoder, which then interprets the signal.

Unlike the Passkey system, Passlock must detect the correct R-Code at the correct time. The Passlock I system uses a bulb check wire to activate the IPC module. This wire is not present in the Passlock II system. In the Passlock I system, the bulb check wire is

switched to ground when the ignition switch is turned to the crank position. This initiates a time window during which the IPC analyzes the R-Code. If the R-Code is valid and received in the proper window of time, the IPC sends a code via data bus to the Powertrain Control Module (PCM) to enable the fuel system. The vehicle will then start and stay running. If the R-Code is incorrect, the vehicle will start and run for a moment and then shut off.

Passlock II also uses an R-Code, but rather than going through the IPC, the signal is sent directly to the BCM. The Passlock decoder, built into the BCM, then interprets the signal.

Harness 1		
1	GREEN/BLACK	(+) Starter (from vehicle)
2	BLACK/WHITE	Bulb check
3	BLACK	Passlock ground input
4	PINK	(+) Ignition (from vehicle)
5	BLUE	(-) Status (from remote start system)
6	VIOLET	(-) Starter (from remote start system)
7	RED	(+) 12V (+ battery)
Harness 2		
1	WHITE	R-code
2	YELLOW	R-code
3	WHITE/YELLOW	R-code in
4	BLACK/YELLOW	R-code BCM

**IMPORTANT!** See instructions for passlock system that applies for harness 2.

## Passlock I Wiring Diagram

**IMPORTANT!** Do not attempt to use the 556L before learning the Resistance Code. (See Learning the Resistance Code section of this manual.)

## Wire Connection Guide for Passlock I

**GREEN/BLACK:** Not used for this application.

**BLACK/WHITE (-) output to bulb check wire:** Connect this wire to the 20-gauge BLACK bulb check wire in the ignition switch power harness. This wire will test (-) ground only when the ignition switch is turned to the crank position. Do not connect to the black wire in the three-wire Passlock cable.

**BLACK (-) Passlock ground input:** Connect this input to the Passlock system's ground reference wire.

**PINK (+) ignition input:** Connect this wire to the heavy gauge positive (+) PINK wire of the vehicle's main ignition.

**BLUE (-) status input:** Connect this wire to the (-) status output (BLUE/WHITE or BLUE) of the Directed remote start system.

**VIOLET (-) input from starter relay:** Connect this wire to the (-) starter output of the remote start system. This is the VIOLET ribbon

harness wire of the pre-wired relay pack. To verify the correct wire, test using a digital multimeter and verify that (-) chassis ground is present on this wire while the remote start system is engaging the starter motor.

**RED (+) 12 volt input:** Connect this wire to a source of constant 12 volts. This wire has a 5-amp fuse.

**WHITE:** Not used for this application.

**YELLOW R-Code, ignition switch:** Connect this wire to the ignition switch side of the resistance wire in the three-wire Passlock cable in the vehicle.

**WHITE/YELLOW:** Not used for this application.

**BLACK/YELLOW R-Code, output to vehicle side:** Connect this wire to the side of the resistance wire facing away from the ignition switch. This wire is located in the vehicle's three-wire Passlock harness.

## Passlock I Wiring Diagram

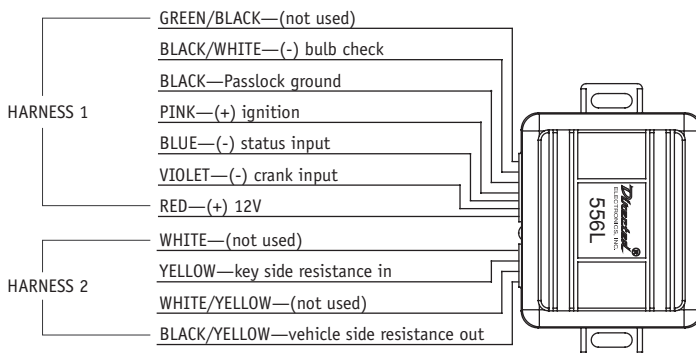

## Passlock I Programming

The module must first be programmed before operation, use the following procedure:

**IMPORTANT!** The vehicle must be started within 15 seconds or the module will automatically exit the learn routine.

1. Cycle the ignition On/Off 2 times.
2. Start the vehicle and keep it running for at least 10-seconds.
3. The LED on the module will flash 2-times.

4. Wait for the LED to flash once very quickly (within 5-seconds) of ignition On. The R-code is learned.
3. Programming is now complete. Turn the vehicle's ignition off and test remote start at least twice.

**NOTE:** Refer to the end of this document for troubleshooting procedures.10. Programming is now complete. Reconnect starter wire. Test remote start at least twice.

**NOTE:** Refer to the end of this document for troubleshooting procedures.

## Wire Connection Guide for Passlock II

**GREEN/BLACK:** Not used for this application.

**BLACK/WHITE:** Not used for this application.

**BLACK (-) Passlock ground input:** Connect this input to the Passlock system's ground reference wire.

**PINK (+) ignition input:** Connect this wire to the heavy gauge positive (+) PINK wire of the vehicle's main ignition.

**BLUE (-) status input:** Connect this wire to the (-) status output (BLUE/WHITE or BLUE) of the Directed remote start system.

**VIOLET (-):** Not used for this application.

**RED (+) 12 volt input:** Connect this wire to a fused source of constant 12 volts.

**WHITE:** Not used for this application.

**YELLOW R-Code, ignition switch:** Connect this wire to the ignition switch side of the Passlock II system's cut resistance wire.

**WHITE/YELLOW:** No connection.

**BLACK/YELLOW R-Code, output to vehicle side:** Connect this wire to the side of the resistance wire facing away from the ignition switch.

## Passlock II Wiring Diagram

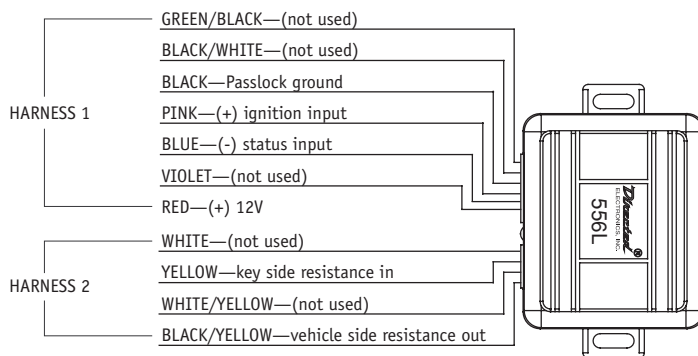

## Passlock II Programming

The module must first be programmed before operation, use the following procedure:

**IMPORTANT!** The vehicle must be started within 15 seconds or the module will automatically exit the learn routine.

1. Cycle the ignition On/Off 2 times.
2. Start the vehicle and keep it running for at least 10-seconds.
3. The LED on the module will flash 2-times.

4. Wait for the LED to flash once very quickly (within 5-seconds) of ignition On. The R-code is learned.
3. Programming is now complete. Turn the vehicle's ignition off and test remote start at least twice.

**NOTE:** Refer to the end of this document for troubleshooting procedures.

## Wire Connection Guide for Canyon/Colorado Interface

**GREEN/BLACK (+) starter wire.**

**BLACK/WHITE:** Not used for this application.

**BLACK (-) Passlock ground input:** This wire must be connect to a good chassis ground.

**PINK (+) ignition input:** Connect this wire to the heavy gauge positive (+) PINK wire of the vehicle's main ignition.

**BLUE (-) status input:** Connect this wire to the (-) status output (BLUE/WHITE or BLUE) of the Directed remote start system.

**VIOLET (-):** Not used for this application.

**RED (+) 12 volt input:** Connect this wire to a source of constant 12 volts. This wire has a 5-amp fuse.

**WHITE R-Code, key side:** Connect this wire to the ignition switch side of the Passlock system's cut resistance wire..

**YELLOW:** Not used for this application.

**WHITE/YELLOW:** Connect to the uncut reference resistance in wire of the ignition switch.

**BLACK/YELLOW R-Code, output to vehicle side:** Connect this wire to the side of the resistance wire facing away from the ignition switch.

## CANYON/COLORADO Wiring Diagram

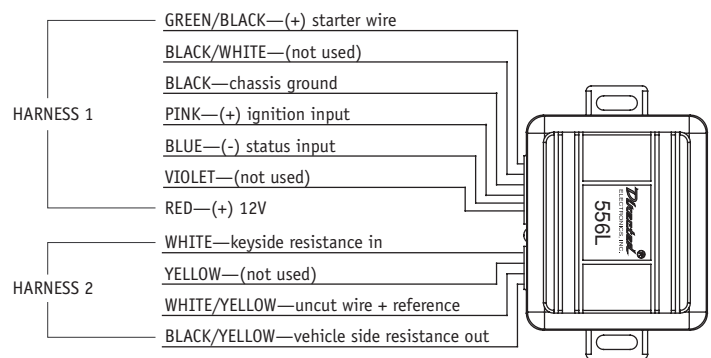

## CANYON/COLORADO Wiring Interface

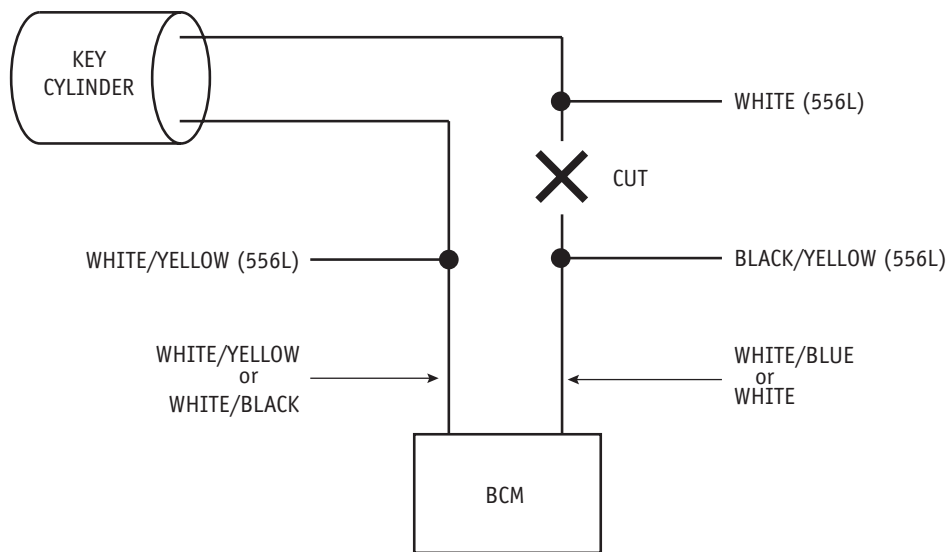

## CANYON/COLORADO Programming

The module must be programmed before first operation, use the following procedure:

**IMPORTANT!** *The vehicle must be started within 15 seconds or the module will automatically exit the learn routine.*

1. Cycle the ignition On/Off four times (1/2 to 1 second).
2. On the 5<sup>th</sup> time crank the engine and hold in that position.
3. There will be a series of 4 flashes, continue to hold in the crank position for 10-20 seconds until a 5<sup>th</sup> quick flash is obtained.
4. The R code is now learned, turn the engine off and remove the ignition key.
5. Programming is now complete. Test the remote start at least twice.

## Vehicle Application Guide

Refer to vehicle specific information on DirectWire or refer to document 1059.

## Troubleshooting Passlock 1

If the vehicle remote starts and then quickly dies, follow the below steps in order to resolve the problem.

1. Shut down the remote start
2. Is the Theft System light flashing or off? If the light is off advance to step 3. If the light is flashing advance to step 4.
3. Start the vehicle with the key.
  - If the vehicle starts make sure the BLACK wire on the 556L is soldered to the center BLACK wire of the vehicle passlock wires, also verify that the bulb check wire has been correctly identified and is soldered to the BLACK/WHITE wire of the 556L, Check the connection on the VIOLET wire of the 556L to the relay satellite ribbon harness VIOLET wire, both of these wires are required for passlock 1.
  - If the vehicle does not start and the Theft System light remains solid, recheck all connections and meter the passlock wires to verify you have interfaced with the correct wires.
4. Wait five seconds and attempt to restart the vehicle with the key. If the vehicle will not start with the key advance to step 5. If the vehicle starts and stays running, recheck all connections. The vehicle has entered Short Tamper mode caused by a failure of the passlock module to read the R-code within the time window allowed, verify that the blue/black off the 556L is seeing a ground trigger when remote started, and is soldered to the Blue status output from the remote start unit. If 3 attempts are made to start the vehicle in which no R-code is read the passlock system will enter Long Tamper mode
5. The system has entered Long Tamper mode, this mode will not allow the vehicle to start for 10 minutes, long tamper mode is almost always caused by the wrong R-code being sent to the passlock module. This will immediately cause a No-Start condition, even if an attempt is made to start the vehicle with the key, In this case wait 10 minutes and reattempt to learn the R-code after all connections have been verified.

## Troubleshooting Passlock 2

If the vehicle remote starts and then quickly dies, follow the below steps in order to resolve the problem.

1. Shut down the remote start.
2. Is the Theft System light flashing or off? If the light is off advance to step 3. If the light is flashing advance to step 4.
3. Start the vehicle with the key.
  - If the vehicle starts, use a meter to confirm that the correct wires have been interfaced. Verify all connections and make sure the BLACK wire on the 555L is soldered to the ORANGE/BLACK or BLACK wire of the vehicle passlock wires. Then verify that the VIOLET and BLACK/WHITE wires from the 555L are NOT connected to anything, the YELLOW goes to the key cylinder side of the yellow passlock wire, and the BLACK/YELLOW goes to the car side of the YELLOW passlock wire.
  - If the vehicle does not start with the key advance to step 4.
4. Wait five seconds, then attempt to start the vehicle with the key.
  - If the vehicle will not start with the key advance to step 5.
  - If the vehicle starts and stays running, recheck all connections. The vehicle has entered the Short Tamper mode. This is caused by a failure of the passlock module to read the R-code within the time window allowed. Verify that the BLUE/BLACK wire off the 555L is seeing a ground trigger when remote started and is soldered to the BLUE status output from the remote start unit. If three attempts are made to start the vehicle in which no R-code is read the passlock system will enter Long Tamper mode.
5. The system has entered Long Tamper mode. This will not allow the vehicle to start for 10 minutes. Long tamper mode is almost always caused by the wrong R-code being sent to the passlock module. This will immediately cause a No-Start condition, even if an attempt is made to start the vehicle with the key. In this case wait 10 minutes and reattempt to learn the R-code after all connections have been verified.





© 2005 Directed Electronics, Inc. Vista, CA  
N556L 05-05