

Product Description

The 555C provides an easy way for interfacing remote start products with vehicles' OEM transponder-based anti-theft systems, while maintaining the integrity of the OEM systems. The 555C uses a very small electronic chip hidden in the top of the key to send a code to the vehicle's transceiver whenever the ignition is energized. For this to happen the key must be placed in the ignition and turned to the RUN position. This energizes a coil surrounding the key, which in turn energizes the chip which sends the signal to the vehicle. If the vehicle does not detect the code being sent, the car will start and then immediately shut off and the anti-theft light will flash. The 555C will provide a valid code to the vehicle whenever it is remote started, but will have no affect on the OEM anti-theft system during normal operation of the vehicle. The OEM transponder-based anti-theft system remains fully functional.

IMPORTANT! *The 555C interface module is designed to work with DEI remote start systems that have a wait-to-start input wire. This wire delays cranking of the starter and is required for programming the 555C. Some non-DEI remote start systems may not have a wait-to-start input, and therefore may not be compatible with the 555C interface module.*

Identifying the Antenna Ring

Remove the steering column shroud and locate the ignition switch. There is a plastic ring surrounding the ignition switch, which is the coil or antenna ring where the 555C chip will be mounted. After programming of the 555C is complete, mount the chip securely in a location appropriate to the vehicle make and model.

Wire Connection Guide

RED (+)12V: Connect this wire to a fused (+)12V source.

BLUE (-) ACTIVATION INPUT: Connect this wire to the (-) through activation output of the remote start system.

555C CHIP: The chip should be placed on the outside of the antenna ring as close to the ribbon cable as possible.

NOTE: *The example for capsule mounting location shown at the right is provided as a general reference only. Actual mounting locations for other vehicle makes and models may vary. Additional capsule mounting locations for specific vehicles can be found on DEI's technical website, www.directechs.com.*



2000 Jeep Cherokee

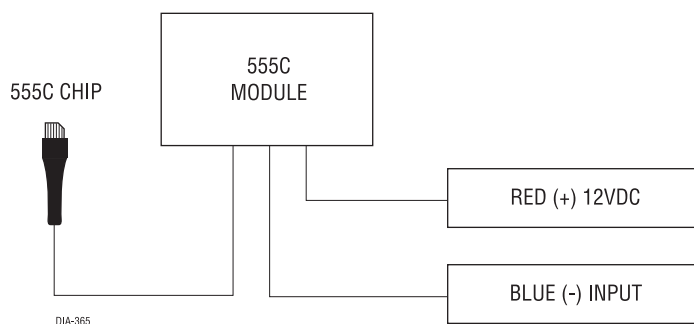

Programming the 555C

NOTE: When programming the 555C, you must have two separate keys that are already coded to the vehicle. Using the same key twice will not work. Also, make sure the two keys are not on the same key ring, because this may also cause the car not to learn the 555C chip.

1. Install the remote start and make the appropriate wire connections to the 555C.
2. Make sure that the 555C chip can reach the front of the key cylinder where the key is inserted.
3. Temporarily ground the wait-to-start input of the DEI remote start system to an acceptable ground source.
4. Insert one of the programmed keys into the ignition lock cylinder and turn the ignition to the RUN position for approximately 8 seconds. Then turn the ignition to the OFF position and remove the key.
5. Within 10 seconds, insert the second programmed key into the ignition lock cylinder and turn the ignition to the RUN position for at least 10 seconds. Depending on the model, the Vehicle Theft Security System (VTSS) or Sentry Key Immobilizer System lamp will start to flash. The flashing lamp, along with an audible tone, will indicate that the system has entered the “learn routine” programming mode. After you have received programming confirmation, turn the ignition to the OFF position and remove the key.
6. Within 10 seconds, hold the 555C chip in front of the key cylinder, approximately half an inch away from the key hole. Activate the DEI remote start system. The ignition and accessories should turn on, but the vehicle should not crank (due to the wait-to-start input being grounded). Allow the vehicle to remain with the ignition and accessories on while holding the 555C chip in front of the key cylinder. After approximately 10 seconds, a tone will sound and the indicator lamp will stay illuminated for 3 seconds. This will be the confirmation that you have successfully programmed the 555C, and the remote start system can be shut off.
7. Remove the wait-to-start input wire of the remote start system from ground. The wait-to-start input will no longer be needed unless the vehicle is a diesel. If the vehicle is a diesel, the wait-to-start input should now be connected to the vehicle’s wait-to-start wire.
8. Attempt to remote start the vehicle while holding the chip in front of the key cylinder. If the vehicle starts then proceed to Step 9. If it does not start, go back to Step 3 and repeat Steps 3 through 8.
9. Place the 555C chip against the immobilizer antenna ring and activate the remote start. If the vehicle starts, attach the chip securely. If the vehicle does not start, move the chip and try to remote start the vehicle again. Repeat this process until the vehicle starts and then secure the chip.